

Application Note
AN1405

Revision:	03
Issue date:	2017-12-07
Prepared by:	Rainer Weiss
Approved by:	Ulrich Nicolai

Keyword: Clearance, Coordination, Creepage, Drive, Insulation, Isolation, Module, Photovoltaic, Solar, Solid, Standard

Coordination of insulation

1. General	1
2. Types of Insulation	2
2.1 Functional insulation	2
2.2 Basic insulation	2
2.3 Protective separation	2
3. Realization of Insulation	3
3.1 Clearance	3
3.2 Creepage	4
3.3 Solid insulation	5
4. Standards.....	5
4.1 European and international standards.....	5
4.2 UL standards	6
5. SEMIKRON Modules	8
6. Example AC Drive.....	8
6.1 Specification	8
6.2 Clearance	9
6.3 Creepage	10
6.4 Solid insulation	13
6.5 Summary AC-drive	14
7. Example Photovoltaic Converter	15
7.1 Specification	15
7.2 Clearance	16
7.3 Creepage	18
7.4 Solid insulation	22
7.5 Summary photovoltaic converter	23

1. General

An electrical insulator is a material that makes it very hard to conduct an electric current under the influence of electric voltage. The perfect insulator does not exist. A portion of the insulator could become electrically conductive if the voltage applied exceeds a critical level. Insulators are used in all electrical equipment to separate electrical conductors without allowing current flow between them. The performance of the insulation must be so good that the insulator withstands the electric stress over long time in the environment of the application. A lot of experience has been collected about insulation over the years, which has been documented in several standards. Rules for coordination of insulation bring the voltage stress requirements for electrical insulation given from the application in line with the necessary insulation withstand capability based on the experience of a standard.

This application note is written for technicians and engineers with some experience in power electronics and some experience to the relevant standards for the coordination of insulation. The two examples are a motor drive and a photovoltaic converter with 3-level technology. This note is a guide how to understand

the insulation standards in general but also focuses on the drive- and the photovoltaic converter standards. It also shows how SEMIKRON performs the coordination of insulation for its products. This application note will not substitute reading the relevant application standard itself.

Very often, the English words insulation and isolation are mixed up. Insulation refers to a material that wraps around or covers an electrical element to protect it from the environment. Isolation means separating the electrical element from other electrical parts so that it stands alone. This application note refers to materials including air that cover electrical elements, so the word insulation is used.

2. Types of Insulation

The coordination of insulation differs between three kinds of insulation subject to their purpose. They must fulfil hierarchically graded requirements.

2.1 Functional insulation

Functional insulation separates potentials within a circuit and considers purely functional, but not safety relevant aspects.

In power electronic devices like converters this is between the input and output terminals or on the module level between the power terminals like AC, DC or brake chopper and IGBT-control terminals like gate or emitter.

2.2 Basic insulation

Basic insulation separates grid-supplied circuits from earthed exposed parts and is thus vital for safety. A breakdown of the insulation does not result automatically in a danger of life due to the earthing of the exposed parts.

This is between earthed heatsinks, housings or module base plates on the one hand and converter input and output terminals or module power terminals on the other hand.

2.3 Protective separation

Protective separation realized by reinforced or double (2 · -basic) insulation separates grid supplied circuits from unearthed exposed parts, on the one hand, and from control circuits, if they are directly connected to other control circuits which have exposed components. No further protection is provided for equipment users. A breakdown of this insulation could be fatal because the unearthed exposed parts can be shifted to the grid voltage. This is the reason why stricter requirements must be fulfilled.

Protective separation is between converter input and output terminals or module power terminals on the one hand and its insulated internal control circuit or sensors on the other hand. These sensors are for current, voltage or temperature, whose outputs may be connected to the control circuit with exposed parts; e.g. pins of a connector or a touch panel. Further protective separation is necessary between the power circuit and the control circuit with exposed parts on power module driver boards.

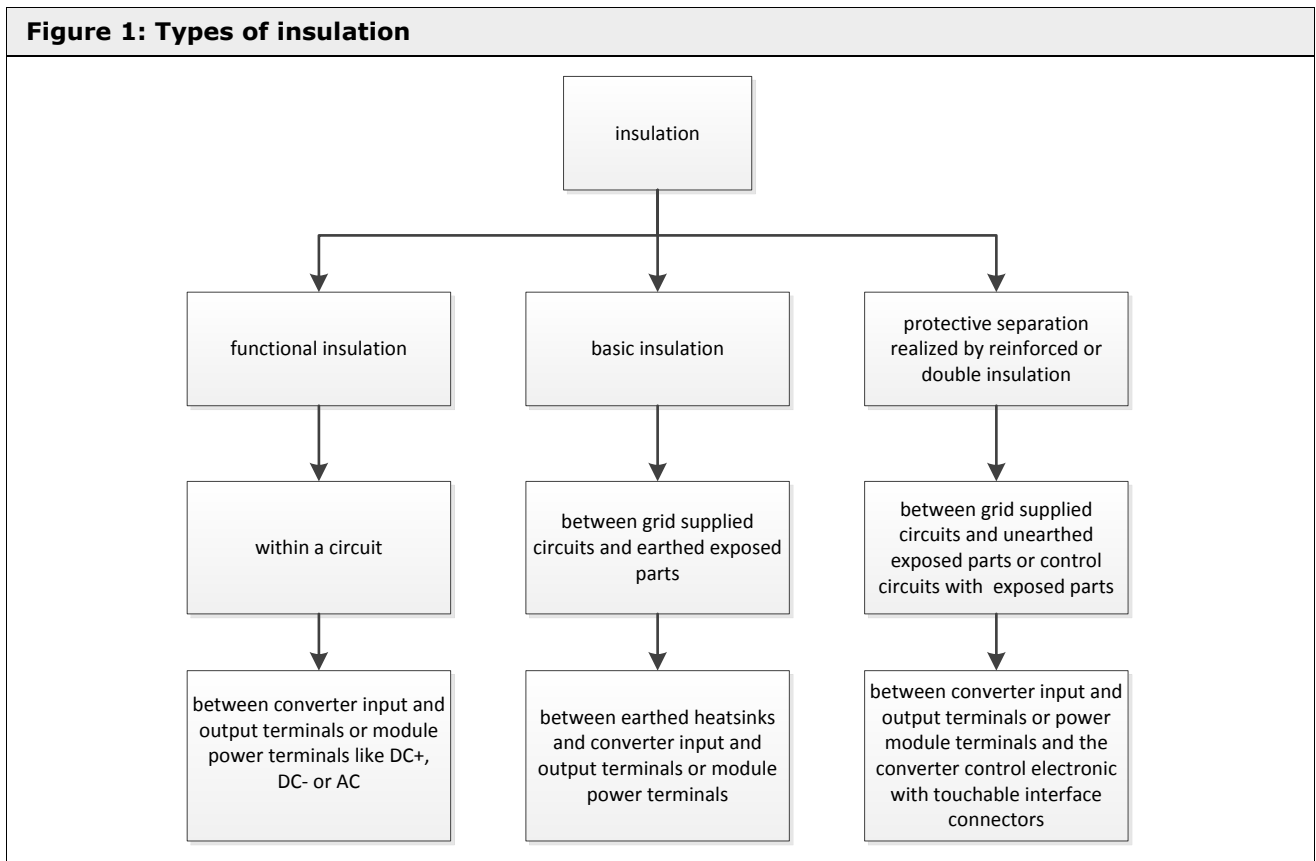

3. Realization of Insulation

Insulation can be implemented as clearance, creepage, solid insulation or a combination of these three.

3.1 Clearance

The air space between conductive parts is called clearance. It must be so large that flashover is prevented at all times if voltage is applied. The determining factors for this are the highest peak voltage present and the dielectric strength of the ambient air. The peak voltage is considered by the overvoltage category of the equipment energized from grid. The overvoltage category level is the degree for the expected overvoltage. In special protected circuits expected voltages are lower (= low category level) than in circuits where lightning strike can occur (= high category level). The four existing categories are described in all insulation standards with slightly different explanations but the same meaning.

Table 1: Overvoltage categories according to EN61800-5-1, 4.3.6.1.3	
Overvoltage Category (OVCAT)	Description
1	Equipment connected to a circuit where measures have been taken to reduce transient overvoltages to a low level
2	Equipment not permanently connected to the fixed installation
3	Equipment permanently connected in fixed installations (downstream of, and including, the main distribution board)
4	Equipment permanently connected at the origin of an installation (upstream of the main distribution board)

The installation altitude has a high impact on the dielectric strength of the air due to the decreasing air pressure. If the installation altitude is >2000m above sea level, the required clearance must be enlarged by an altitude correction factor which is given in EN60664-1, table A2. The standard does neither forbid nor permit interpolation for altitudes between the lines of the table. It is usual and it makes physically sense to interpolate.

Table 2: Altitude correction factor according to EN60664-1, table A2		
Altitude [m]	Normal barometric pressure [hPa]	Multiplication factor for clearance
2000	800	1.00
3000	700	1.14
4000	620	1.29
5000	540	1.48
6000	470	1.70
7000	410	1.95

3.2 Creepage

Pollution on the surface of insulating material can create a conductive path across it. The length of this conductive part is called creepage length, creepage track or simply creepage. Dirt, salt, water and the applied voltage have an impact on the length of the conductive path.

The level of pollution and the resistance of the materials used with regard to the surface currents determine the dimensioning of the creepage. The environmental conditions correlate to four degrees of pollution.

Table 3: Pollution degrees according to EN61800-5-1, 4.3.6.1.2	
Pollution degree (PD)	Description
1	No pollution or only dry, non-conductive pollution occurs. The pollution has no influence.
2	Normally, only non-conductive pollution occurs. Occasionally, however, a temporary conductivity caused by condensation is to be expected, when the device is out of operation. Some standards like EN50124-1 expect temporary conductivity caused by condensation in operation also.
3	Conductive pollution or dry non-conductive pollution occurs, which becomes conductive due to condensation, which is to be expected.
4	The pollution generates persistent conductivity caused, for example by conductive dust or rain or snow.

The resistance of the insulating material is described by the comparative tracking index (CTI). It is determined by increasing a test voltage until a specified leakage current will flow in a defined test setup. The more resistant a material is, the higher the CTI-value and the shorter the creepage track may be. Insulating materials are classified in five groups.

Table 4: Comparative tracking index (CTI) groups

CTI group	CTI level	Example
0		Inorganic materials like glass or ceramic which do not track
1	≥600	Plastic material like PE-HD (polyethylene) or PTFE (polytetrafluoroethylene)
2	400...599	Printed circuit board (PCB) base material FR4 type KF
3a	175...399	Glass-filled PCB material FR4
3b	100...174	Foil material polyimide (e.g. Kapton) or resins (e.g. phenolic)

The damaging effect of creepage currents is a longtime issue. What is decisive here is the effective value of the applied voltage, not its peak value. The period for the calculation of the effective voltage is for this reason at least the cycle time of the application.

The phase shift between the first harmonic of the voltages must be considered by adding RMS-voltages. Often the shift is unknown or only identifiable with high effort. This is why the worst case is considered and the quadratic sum of voltages is used ($V_{1,3} = \sqrt{V_{1,2}^2 + V_{2,3}^2}$). On the other hand, this means that the resulting sum of voltages is sometimes no conclusive.

The minimum creepage lengths required in standards were mostly determined empirically, with the tracking resistance of printed circuit boards (PCB) determined only for voltages up to 1000V and pollution degrees 1 and 2 in experimental setups, with the results adopted as a requirement. This is why the required distances here are much smaller than the CTI of the PCB material would actually require.

The minimum creepage is at least the clearance. This is why the creepage length must be at least as large as the clearance in air. For inorganic insulating materials like glass or ceramic, which do not track, the creepage distance may equal the associated clearance.

3.3 Solid insulation

Solid insulation is insulation not created solely by air or gas. Some standards require minimum material thicknesses, do not accept coating as insulation material or have special requirements for PCBs. It is not possible to generalize the demands and the relevant product standard must be checked. To verify if the solid insulation withstands the voltage load, three tests can be performed:

- Impulse withstand voltage test
- a.c. or d.c. voltage test
- Partial discharge test

Ideally, the partial discharge inception voltage is higher than the maximum peak voltage to be expected because then partial discharge will never occur. The partial discharge extinction voltage must be higher than the continuously present voltage because when partial discharge starts it must be safely interrupted again. Some standards require a partial discharge test for protective separation insulation only. It is permitted to perform the tests on the component rather than on the equipment.

Coordination of insulation is to correlate the types and the realization of the insulation for each potential within the converter and find out the minimum requirements like distances or test voltages what the relevant standard requests.

4. Standards

4.1 European and international standards

High voltage equipment ($>1000V_{ac}$ or $1500V_{dc}$) and low voltage equipment ($\leq 1000V_{ac}$ or $1500V_{dc}$) must be considered separately. Both have their own basic standards with fundamental requirements. For high voltage equipment connected to the grid, it is EN60071-1 and for low voltage equipment, it is EN60664-1. Product standards and product group standards usually refer back to these basic standards so the requirements for all equipment are broadly independent of the used standard. There are some typically applied standards for the coordination of insulation of converters.

Standards for equipment not connected to the grid are normally not based on the named basic standards. They occasionally demand severe requirements for the insulation, e.g. EN50124-1 for railway applications.

Table 5: Selection of European standards for the coordination of insulation		
EN60071-1	Insulation coordination – Definitions, principles and rules	basic standard
EN60664-1 [3]	Insulation coordination for equipment within low-voltage systems - principles, requirements and tests	basic standard
EN50178	Electronic equipment for use in power installations	product group standard
EN62477-1 [4]	Safety requirements for power electronic converter systems and equipment – general	product group standard
EN60950-1	Information technology equipment – safety – general requirements	product standard
EN61204-7	Low voltage power supplies, d.c. output – safety requirements	product standard
EN61800-5-1 [5]	Adjustable speed electrical power drive systems – safety requirements – electrical, thermal and energy	product standard
EN62040-1	Uninterruptible power systems (UPS) – general and safety requirements for UPS	product standard
EN62109-1 [6]	Safety of power converters for use in photovoltaic power systems - general requirements	product standard
EN50124-1	Railway applications - insulation coordination - basic requirements - clearances and creepage distances for all electrical and electronic equipment	product standard

4.2 UL standards

In general, coordination of insulation for UL is not based on IEC- or EN-standards. The requirements differ considerably for this reason. If a UL-approval for equipment is intended, the coordination of insulation will be done twice: One time for European/international standards and one time for UL.

The UL basic requirements for the insulation are established for phase-to-ground rated system voltages up to 1500V in the UL-standard UL840. The requirements of various UL product standards are established on this basic standard or they allow using the insulation requirements of this basic standard alternatively.

Most UL-standards do not allow differing between functional and basic insulation what most times results in higher clearances within the circuit in comparison to the IEC- and EN-standards. Normally equipment designed according to IEC- and EN-standards only does not fulfil the UL insulation requirements.

Table 6: Selection of UL standards for the coordination of insulation			
UL840	Insulation coordination including clearances and creepage distances for electrical equipment	basic standard	
UL508A	Industrial control panels	product standard	UL840 can be used alternatively
UL508C	Power conversion equipment	product standard	UL840 can be used alternatively
UL1741	Inverters, converters, controllers and interconnection system equipment for use with distributed energy resources	product standard	UL840 can be used alternatively
UL61800-5-1 [7]	Adjustable Speed Electrical Power Drive Systems – Part 5-1: Safety Requirements – Electrical, Thermal and Energy	product standard	no alternative use of UL840

UL61800-5-1 has been released to eventually replace UL508C. Since 2016, UL61800-5-1 is used for determining the insulation coordination of new products. UL 508C will be withdrawn in 2020. A summary of the significant differences between UL61800-5-1 and UL508C is available on the UL-homepage [8][8]. UL61800-5-1 is not the same as EN61800-5-1. Significantly different are e.g. the spacings at the field wiring terminals of a drive. UL61800-5-1 requests here higher distances. A list of the differences is in the foreword of UL61800-5-1.

The structure of typical used standards for the insulation coordination of industrial applications is shown below.

Figure 2: Structure of selected standards for the coordination of insulation of converters

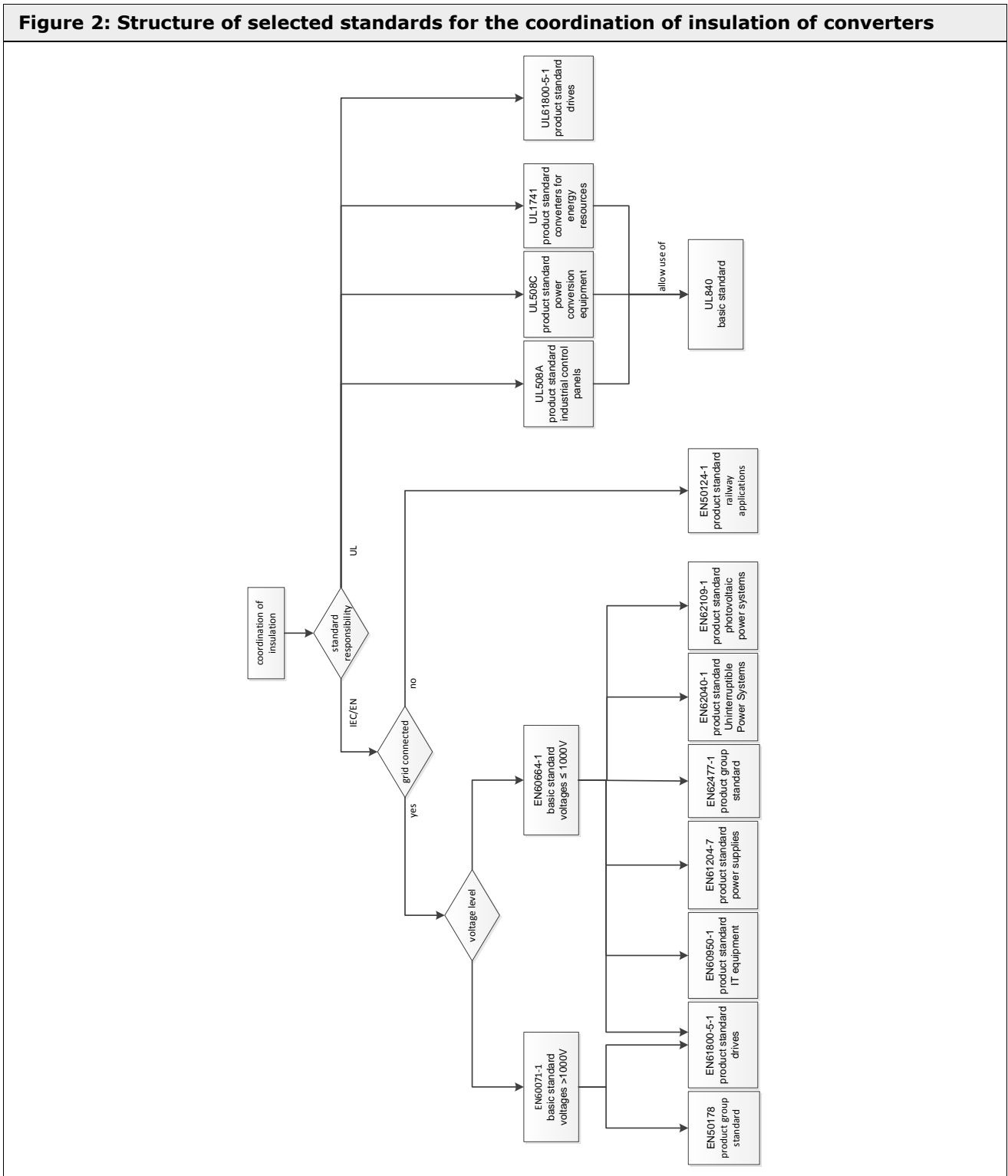

5. SEMIKRON Modules

Typically, SEMIKRON components are designed according to the standard EN61800-5-1. If not stated otherwise in the component datasheet, the dimensioning of the insulation depends on the blocking voltage class of the module. Modules of the same product line with the same housing size are designed for the highest available blocking voltage of this module type. A MiniSKiiP 38ACxxx, for example, is available with 600V, 1200V and 1700V chips. Apart from the chip voltage, the same housing is always used. The dimensioning of the insulation is performed for the highest voltage (e.g. 1700V) module.

Table 7: Typical specification SEMIKRON uses for the coordination of insulation according to EN61800-5-1

Blocking voltage class	DC-link voltage	Grid voltage	Grid configuration	Overvoltage category	Altitude	Pollution degree
600V/650V	400V	230V	star (wye) earthed TN-C-system	3	2000m	2
1200V	900V	480V				
1700V	1200V	690V				

Per the definitions in 2, module terminals have functional insulation between them. Between the terminals and the baseplate, basic insulation is used. In modules with an integrated "potential free" temperature sensor (as shown in the data sheet schematic), functional insulation is used between the sensor and the power circuit.

The module insulation test voltage, V_{isol} , given in the SEMIKRON datasheets shows higher voltages than EN61800-5-1 requests. This is because the modules can be used according to other standards, such as railway applications. It is therefore not possible to conclude from the given test voltage which specification was used for insulation coordination.

6. Example AC Drive

6.1 Specification

An industrial AC drive has the following specification relevant for the process of the insulation coordination:

- Input: 3 x 400V, 50Hz, TN-C system only
- Output: 3 x 370V, 0 to 300Hz
- Brake chopper: DC-turn-on level 830V, DC-turn-off level 800V
- DC-link: $\leq 845V$
- Altitude: $\leq 4000m$
- Pollution: no conductive dust, no condensation
- Fieldbus interface: CAN
- Encoder interface: resolver
- Controller supply: 24V PELV

Other parameters are not relevant for the dimensioning of the insulation.

Figure 3: Principal schematic of the AC drive

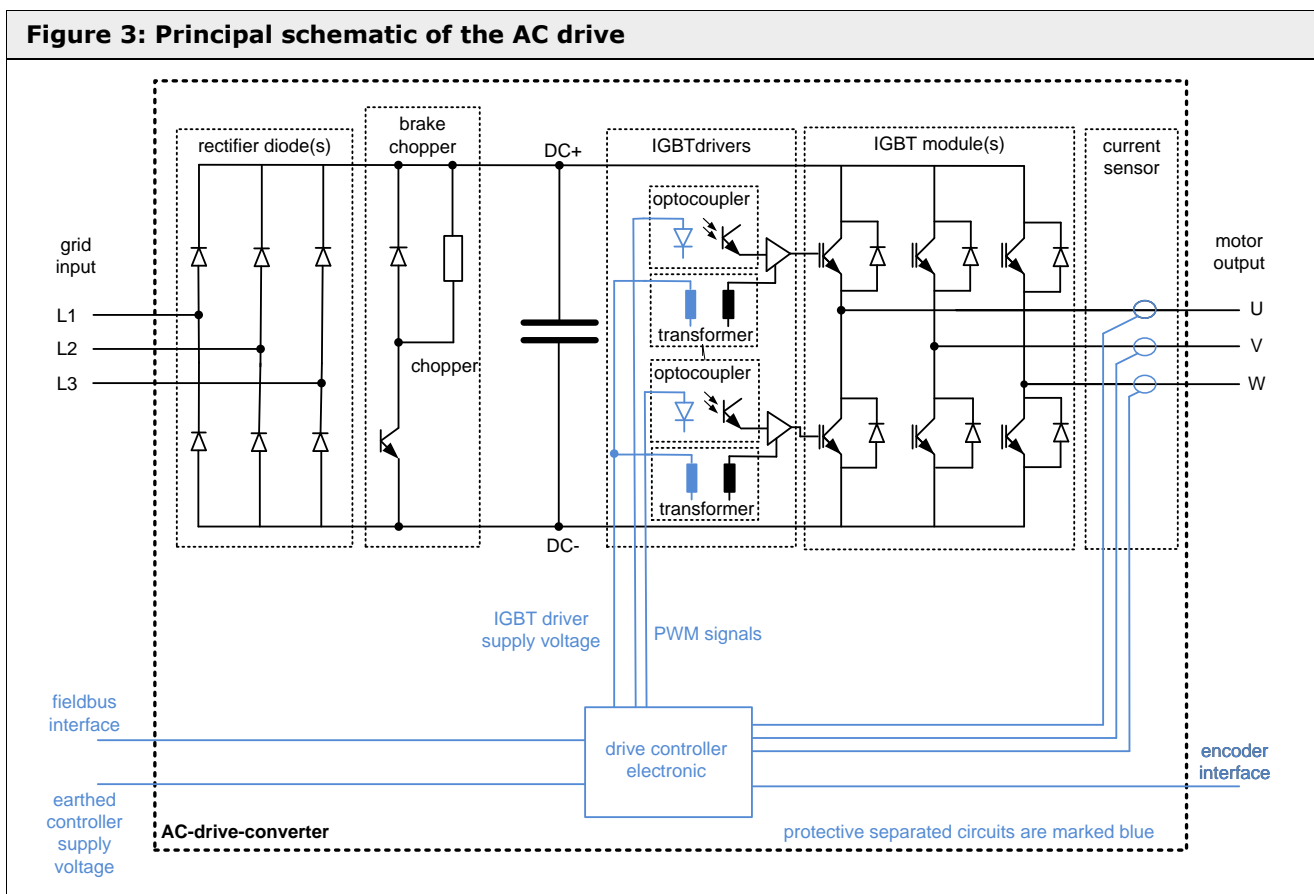

For drives, the relevant product standard is EN61800-5-1. The insulation coordination procedure described in this application note is based on this standard. The applied procedure is similar to the requirements of the product group standard EN62477-1.

With the information that the drive has a wired field bus interface (in this case CAN), an encoder interface (in this case resolver) and an earthed controller supply voltage, it can be presumed that the drive controller electronics are earthed and somehow touchable (e.g. at connector pins). This means that protective separation realized by reinforced or double insulation is necessary between the power circuit and the controller electronics, including the AC drive control interfaces.

The standard introduces the concept of system voltage, which is used to determine insulation requirements. In a TN-C-system with 400V phase-to-phase-voltage (specified input voltage of the drive) the voltage to earth is $400V/\sqrt{3} = 230V$. EN61800-5-1, table 7 does not permit interpolation. Therefore, the next higher value from the table must be taken: 300V. Therefore, the system voltage is here 300V. Insulation is affected by pollution. The information that no conductive dust and no condensation are allowed correlates to pollution degree 2 (EN61800-5-1, table 6).

6.2 Clearance

The drive is specified for altitudes up to 4000m, so an altitude correction factor must be considered for all clearances. The factor for 4000m is 1.29 according to EN60664-1, table A2.

6.2.1 Clearance used as functional insulation

For functional insulation, the recurring peak of the working voltage is relevant. In the worst case, this is the blocking voltage of the used semiconductor modules between all points within the power circuit. According to EN61800-5-1, table 9, columns 2 and 4, a clearance of 0.9mm is necessary for 1200V peak working voltage (assumed that 1200V modules are used for the drive what is typical for the specified AC drive input voltage). The 0.9mm are the result of linear interpolation between the lines of the table with 960V and 1600V what the standard explicitly permits. Here the required distance values are always rounded to one digit in safe direction.

$$d = 0.5\text{mm} + \frac{1.5\text{mm} - 0.5\text{mm}}{1600\text{V} - 960\text{V}} \cdot (1200\text{V} - 960\text{V}) = 0.875\text{mm} \approx 0.9\text{mm}$$

The clearance required for overvoltage category 1 is only 0.5mm and has not to be considered consequentially due to the weaker requirement (the impulse voltage for 300V system voltage and overvoltage category 1 is 1500V according to EN61800-5-1, table 7, column 2 which results in a clearance of 0.5mm according to EN61800-5-1, table 9, column 5). Considering the altitude correction factor of 1.29 the necessary clearance for functional insulation is 1.2mm ($\approx 0.875\text{mm} \cdot 1.29$). This value must be taken for all clearances within the power circuit, e.g. between the phases, from phase to DC or between the gates of the upper (TOP) and the lower (BOT) IGBT.

The real voltages within the power circuit can be lower than the blocking voltage and the clearances could be less for this reason. On the other hand, most of the time creepage lengths are the stronger request for functional insulation, especially if no altitude correction factor must be considered. Therefore, it is not a substantial restriction to take the blocking voltage for the determination of the clearances.

6.2.2 Clearance used as basic insulation

The AC-drive is used in a fixed industrial installation supplied from the grid. The expected overvoltage for such equipment is category 3 (EN61800-5-1, 4.3.6.1.3).

The system voltage (here 300V, see above) and the overvoltage category determine the impulse voltage (EN61800-5-1, table 7, column 4) what is necessary to determine the clearance. For 300V, the impulse voltage is 4000V what correlates to 3mm clearance (EN61800-5-1, table 9, column 5). Working voltages up to 1600V are acceptable for 3mm clearance (EN61800-5-1, table 9, column 3), what is much more than what will be expected in the drive. Therefore the strongest requirement is from the overvoltage category here. Considering the altitude correction factor the necessary clearance for basic insulation is 3.9mm ($\approx 3\text{mm} \cdot 1.29$).

This value must be taken for all clearances between earthed conductive parts like heatsink or housing, and the power circuit, e.g. input terminals, output terminals, the DC-link or exposed parts of the grid voltage circuit on the PCB.

6.2.3 Clearance used as protective separation

The determination of the system voltage, the overvoltage category and the resulting impulse voltage is the same like for basic insulation. The required clearance is higher for protective separation than for basic insulation because a failure could be fatal for the user. The impulse voltage corresponding to the next higher value in the table shall be used, what is 6000V for protective separation realized by reinforced insulation (EN61800-5-1, table 9, column 1). For 6000V impulse voltage the clearance is 5.5mm (EN61800-5-1, table 9, column 5). The required clearance from the working voltage is the same like for basis insulation and is again weaker than the requirement from the overvoltage category. Considering the altitude correction factor the necessary clearance for reinforced insulation is 7.1mm ($\approx 5.5\text{mm} \cdot 1.29$). This distance must be taken for all clearances between power circuit, e.g. input terminals, output terminals, DC-link or IGBT-gates, and the AC drive controller electronic, e.g. encoder interface, current sensor feedback, PWM-signals or the drive controller itself.

6.3 Creepage

Potting or coating material may be used on PCBs to protect against pollution and improves the microenvironment of the parts underneath the protection (EN61800-5-1, 4.3.6.6), where pollution degree 1 applies. The potting or coating material must pass a test according to EN60664-3.

For the AC drive discussed here, it is assumed that no potting or coating material is used to protect against pollution.

6.3.1 Creepage used as functional insulation

Assuming the considered AC drive consists of a PCB only and no other insulation pertinent components, column 3 of EN61800-5-1, table 10 is relevant for the creepage. If other insulators are used, e.g. a foil between the DC+ and DC-, the isolation category of the insulation will be considered by taking the creepage from column 5 to 8. For all creepages, interpolation for the voltage is explicitly permitted.

The RMS voltage between the potentials within the AC drive must be calculated one after another. If no load is applied to the AC drive the DC-link will be exposed to the peak voltage of the grid voltage what is

$$V_{dc} = 400\text{V} \cdot \sqrt{2} = 566\text{V}.$$

Assumed that the chopper works in 1% of the operation time, the DC-link voltage can be calculated to 569V in worst case:

$$V_{dc} = \sqrt{\frac{1}{T} \left(\int_0^{0,99T} (566V)^2 dt + \int_{0,99T}^T (830V)^2 dt \right)} = 569V$$

The effect of the chopper operation on the RMS voltages is so low that it is not considered for the following calculations except for the chopper voltage itself.

The voltage between one of the input phases and DC+ or DC- is calculated to 365V:

$$V_{L,DC+} = \sqrt{(V_{DC+,earth})^2 + (V_{L,earth})^2} = \sqrt{(0,5 \cdot V_{dc})^2 + \left(\frac{V_{LL}}{\sqrt{3}} \right)^2} = \sqrt{(0,5 \cdot 566V)^2 + \left(\frac{400V}{\sqrt{3}} \right)^2} = 365V$$

The voltage from the motor phases to DC+ or DC- is calculated in the same way, but instead of $V_{LL} = 400V$ is $V_{UV} = 370V$ used. Therefore, the voltage is $V_{U,DC+} = 355V$.

The voltage from the input phases to the output phases of the drive is the sum of the voltages to DC+:

$$V_{L1,U} = \sqrt{V_{L1,DC+}^2 + V_{DC+,U}^2} = \sqrt{(365V)^2 + (355V)^2} = 509V$$

The chopper is turned off for 99% of the time. In this period DC+ voltage is applied to the collector of the chopper IGBT. In the remaining 1% of the time, the IGBT is turned on and the chopper turn-off-voltage is applied to the DC-link. The RMS voltage at the collector of the chopper IGBT to DC- is calculated to 563V and to DC+ it is 83V.

$$V_{Chopper,DC-} = \sqrt{\frac{1}{T} \left(\int_0^{0,99T} (566V)^2 dt + \int_{0,99T}^T (2V)^2 dt \right)} = 563V$$

$$V_{Chopper,DC+} = \sqrt{\frac{1}{T} \left(\int_0^{0,99T} (2V)^2 dt + \int_{0,99T}^T (830V)^2 dt \right)} = 83V$$

The voltage from the phases to the chopper-IGBT is the sum of the already calculated voltages between phase and DC+ and between DC+ and chopper.

$$V_{Chopper,L1} = \sqrt{(365V)^2 + (83V)^2} = 374V$$

$$V_{Chopper,U} = \sqrt{(355V)^2 + (83V)^2} = 365V$$

Based on these voltages the creepages are taken from EN61800-5-1, table 10, column 3. Not all voltage levels are present in the table, so the explicitly permitted interpolation can be used. For the voltage $V_{L1,U} = 509V$ for example is the creepage calculated to 2.6mm.

$$d_{L1,U} = 2.5mm + \frac{3.2mm - 2.5mm}{630V - 500V} \cdot 9V = 2,55mm \approx 2,6mm$$

Table 8: Applied RMS voltage and related creepage distance for functional insulation from EN61800-5-1

		L1	L2	L3	DC+	DC-	chopper	U	V	W
		Applied RMS voltage [V]								
L1	Calculated creepage distance from EN61800-5-1, table 10 [mm]		400	400	365	365	374	509	509	509
L2		2.0		400	365	365	374	509	509	509
L3		2.0	2.0		365	365	374	509	509	509
DC+		1.9	1.9	1.9		566	83	355	355	355
DC-		1.9	1.9	1.9	2.9		563	355	355	355
chopper		1.9	1.9	1.9	0.2	2.9		365	365	365
U		2.6	2.6	2.6	1.8	1.8	1.9		370	370
V		2.6	2.6	2.6	1.8	1.8	1.9	1.9		370
W		2.6	2.6	2.6	1.8	1.8	1.9	1.9	1.9	

Considering that the creepage must have at least the distance of the determined clearance of 1,2 mm gives a new table. The increased distance value due to the clearance requirement is marked blue.

Table 9: Applied RMS voltage and required creepage distance for functional insulation of the AC drive

		L1	L2	L3	DC+	DC-	chopper	U	V	W
		Applied RMS voltage [V]								
L1	Required creepage distance considering the clearance [mm]		400	400	365	365	374	509	509	509
L2		2.0		400	365	365	374	509	509	509
L3		2.0	2.0		365	365	374	509	509	509
DC+		1.9	1.9	1.9		566	83	355	355	355
DC-		1.9	1.9	1.9	2.9		563	355	355	355
chopper		1.9	1.9	1.9	1.2	2.9		355	355	355
U		2.6	2.6	2.6	1.8	1.8	1.9		370	370
V		2.6	2.6	2.6	1.8	1.8	1.9	1.9		370
W		2.6	2.6	2.6	1.8	1.8	1.9	1.9	1.9	

The voltage at the gates of the IGBTs is between +15V and -15V to their emitters. This value is so low that the corresponding creepage is only 0.04 mm and not further considered. The creepage from the gates to all other potentials is the same as from the emitter of the same IGBT. So for all upper IGBTs it is the same like for the phases and for the lower IGBTs the same as to DC-.

6.3.2 Creepage used as basic insulation

In a star grounded TN-C-grid the DC-voltage is balanced to earth. Therefore, the voltage from DC+ or DC- to earth is half of the DC-link voltage. The voltage from the input and output phases to earth is the phase-to-phase voltage divided by $\sqrt{3}$. The voltage to the collector of the chopper IGBT is the difference from the DC-voltage to earth and the voltage between DC and the chopper.

$$V_{chopper,earth} = \sqrt{(283V)^2 - (83V)^2} = 271V$$

Next must be checked if the required clearance is higher than the value from the creepage table. If necessary, the creepage must be increased to the clearance level.

Table 10: Applied RMS voltage and required creepage distance for basic insulation									
	L1	L2	L3	DC+	DC-	chopper	U	V	W
Applied RMS voltage [V]	230	230	230	283	283	271	214	214	214
Creepage distance from EN61800-5-1, table 10 [mm]	0.9	0.9	0.9	1.2	1.2	1.2	0.8	0.8	0.8
Required creepage distance considering the clearance [mm]	3.9	3.9	3.9	3.9	3.9	3.9	3.9	3.9	3.9

6.3.3 Creepage used as protective separation

The voltages for the determination of the creepages for protective separation realized by reinforced or double insulation are the same as for basic insulation, but the requirements for the creepage length are higher. The distances from EN61800-5-1, table 10, column 10 must be doubled. Then it must be checked if the clearance is higher than the double distance of the value from column 10. If necessary, the creepage must be increased to the clearance level.

Table 11: Applied RMS voltage and required creepage distance for protective separation									
	L1	L2	L3	DC+	DC-	chopper	U	V	W
Applied RMS voltage [V]	230	230	230	283	283	271	214	214	214
Creepage distance from EN61800-5-1, table 10 [mm]	1.7	1.7	1.7	2.4	2.4	2.4	1.5	1.5	1.5
Required creepage distance considering the clearance [mm]	7.1	7.1	7.1	7.1	7.1	7.1	7.1	7.1	7.1

6.4 Solid insulation

Potting or coating material may be used on PCBs as solid insulation. For this, the potting or coating material must pass a test according to EN60664-3 (EN61800-5-1, 4.3.6.8.4.2).

Here is assumed that the AC drive does not have potting or coating material as solid insulation.

For the inner layers of multi-layer PCBs, the insulation between adjacent tracks on the same layer shall be treated either as a creepage for pollution degree 1 and a clearance in air (see requirements above) or as solid insulation (EN61800-5-1, 4.3.6.8.4.1).

6.4.1 Solid insulation used as functional insulation

In general, the standard has no special requirements for functional insulation if a failure will have no fatal consequences for life. No tests are necessary. If a failure can have fatal consequences, the requirements for functional insulation will be the same as for basic insulation. The voltages that must be considered are the same as for the clearance and creepage. For this AC drive, it is assumed that no fatal consequences will happen.

6.4.2 Solid insulation used as basic insulation

Two tests must be performed on components, subassemblies and layers of multilayer PCBs in order to ensure that the solid insulation withstands the voltage stress. Here is assumed that the AC drive has an earthed inner layer on a PCB for screening.

An impulse withstand voltage test has to be performed as a type and a sample test according to EN61800-5-1, table 19, column 4 whereby interpolation is permitted. The system voltage for an AC drive with 400V phase-to-phase voltage in an earthed TN-C-grid is 230V, so the correlating test impulse withstand voltage is 3300V. For the same system voltage, an AC or DC voltage test shall be performed according to EN61800-5-1, table 21, column 2 with 1430V_{ac} or 2020V_{dc}.

Insulation material thinner than 750µm must not be subjected to mechanical stress what is the case for the inner layer of a PCB.

The outer insulation of an IGBT module from the copper tracks with the chips towards the module baseplate is checked in the same manner. In this case, the solid insulation is a series connection of the module filled with soft mold and the module housing.

6.4.3 Solid insulation used as protective separation

For protective separation, three tests must be performed on components, subassemblies and layers of multilayer PCBs. The here considered AC drive has optocouplers for the PWM signals and a transformer for the supply of the IGBT-gate-driver. It is fed from the controller voltage. They are all mounted on the PCB.

An impulse withstand voltage test has to be performed as a type and a sample test according to EN61800-5-1, table 19, column 5 for a system voltage of 230V. The impulse withstand voltage is 5067V. For the same system voltage, an AC or DC voltage test shall be performed according to EN61800-5-1, table 21, column 3 with 2860V_{ac} or 4040V_{dc}. A routine test is additionally necessary for the transformer according to column 2 with 1430V_{ac} or 2020V_{dc}.

If the voltage across the layers of the PCB is higher than 750V_{peak} and the electrical field in the insulation between the layers is higher than 1000V/mm, a partial discharge test must be performed as a type test (4.3.6.8.2.2). There is only one insulation layer of the PCB used for the protective separation, so an additional sample test must be performed. The transformer used here is designed such that the voltage stress across the insulation is less than 1000V/mm, so no partial discharge test is required for the transformer.

The partial discharge test must be performed according to EN61800-5-1, table 24. AC drives with a DC-voltage of 566V have typically a common-mode-voltage (= voltage to earth) of roughly 1000V_{peak} due to parasitic effects in the motor cables and the motor. Therefore, the peak-voltage of the partial discharge extinction voltage must be at least

$$V_{PDextinction} = 1.5 \cdot 1000V_{peak} = 1500V_{peak}$$

6.5 Summary AC drive

The results of the insulation coordination according to EN61800-5-1 for the example AC drive at 4000m altitude are summarized in the following table:

Table 12: Insulation requirements of the AC drive according to EN61800-5-1				
EN61800-5-1		Type of insulation		
		Functional insulation	Basic insulation	Protective separation
Realization of insulation	Clearance	1.2mm	3.9mm	7.1mm
	Creepage	1.2mm to 2.9mm	3.9mm	7.1mm
	Solid insulation			
	Impulse withstand test voltage	-	3300V	5067V
	AC or DC test voltage	-	1430V _{ac} or 2020V _{dc}	2860V _{ac} or 4040V _{dc}
	Partial discharge extinction voltage	-	-	1500V _{peak}

For a similar application (not a drive, e.g. a converter for heating), the insulation coordination is made according to EN62477-1. The specification is the same as for the AC drive, not considering that a heater will have no brake chopper or encoder. All demands are the same like using EN61800-5-1.

7. Example Photovoltaic Converter

7.1 Specification

A photovoltaic converter has the following specification relevant for the process of the insulation coordination:

- Input photovoltaic voltage: $\leq 1500V_{dc}$
- Output mains voltage: $V_{LL} = 3 \times 400V_{ac}$, 50Hz, TN-C-system only
- Grid transformer ratio $800V_{ac} / 400V_{ac}$
- Grounding resistor at DC-
- Altitude: $\leq 3000m$
- Indoor use in unconditioned room
- Converter enclosure IP54
- Service interface to solar controller

Other parameters are not relevant for the dimensioning of the insulation.

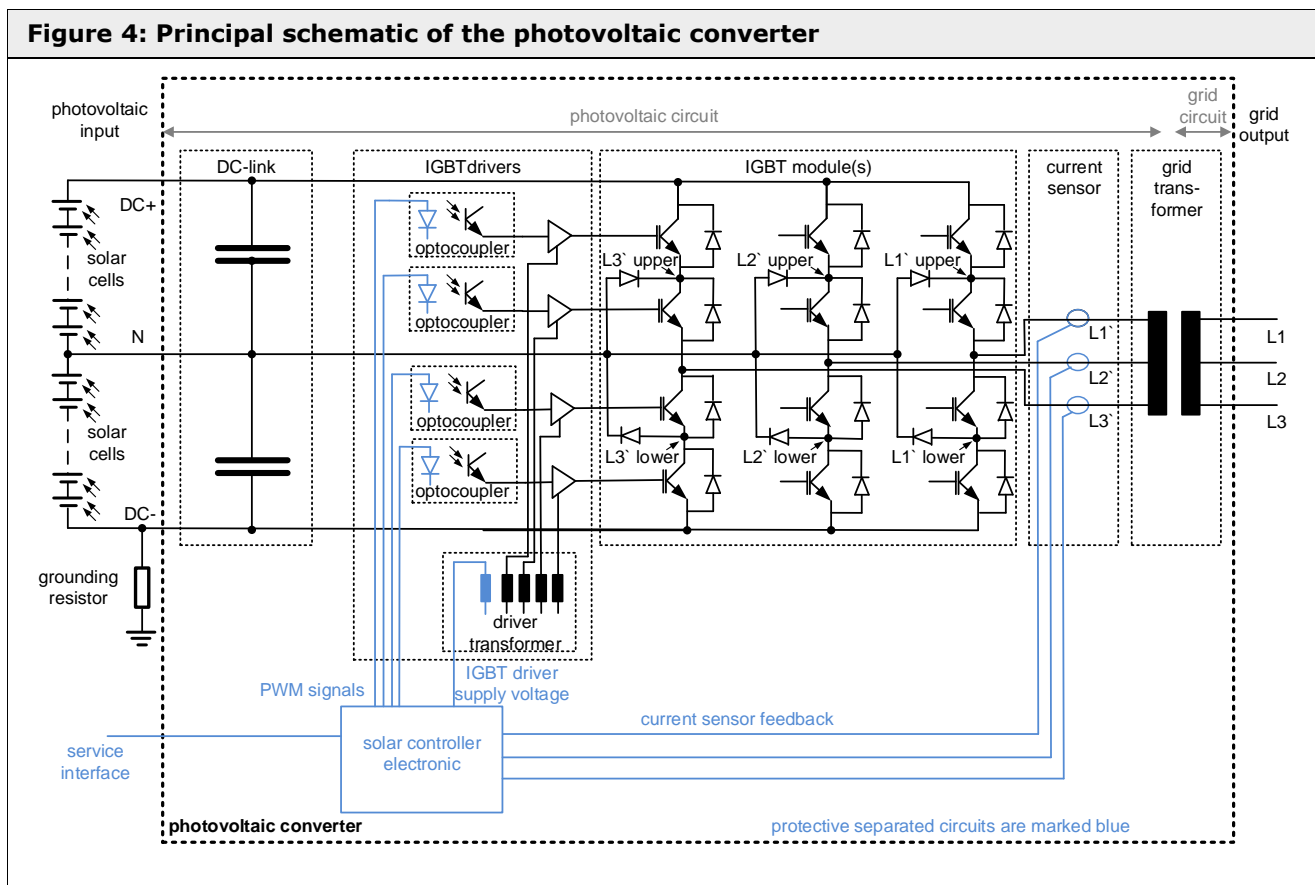

The relevant product standard for photovoltaic converters is EN62109-1. The insulation coordination procedure described here is based on this standard. The procedure is very similar to the requirements of the product group standard EN62477-1.

The information that the converter has a service interface for the solar controller means that protective separation realized by reinforced or double insulation is needed between the power circuit and the controller electronics. Between the power circuit and earthed parts basic insulation is required (EN62109-1, table 8). The power circuit consists of the photovoltaic circuit and the grid circuit. Both are isolated from each other by galvanic isolation using a transformer. Overvoltage category 2 is assumed for the photovoltaic circuit (EN62109-1, 7.3.7.1.2, b) and category 3 for the grid circuit (EN62109-1, 7.3.7.1.2, a). The overvoltage category that applies within the circuit is one category lower (EN62109-1, 7.3.7.1.2, f), here category 1 for the photovoltaic circuit and category 2 for the grid circuit.

Furthermore, it must be considered that the overvoltage level of the grid circuit has an impact on the photovoltaic circuit and vice versa. The galvanic isolation of the grid transformer reduces the overvoltage category by one level in both directions (EN62109-1, 7.3.7.1.2, c).

The system voltage is used to determine the insulation requirements (EN62109-1, 7.3.7.2.1). On the grid side is a TN-C-system with 400V phase-to-phase-voltage (= specified output voltage of the converter). The grid side system voltage here is $400V/\sqrt{3} = 230V$ from phase to earth. The photovoltaic system voltage is the maximum rated photovoltaic open circuit voltage (EN62109-1, 7.3.7.2.3), in this case 1500V. For determining the system voltage, it is irrelevant that the photovoltaic circuit is grounded with a resistor.

Insulation is also affected by pollution. The information that the converter is for indoor use in unconditioned rooms correlates to pollution degree 3 (EN62109-1, table 4). The converter enclosure or the cabinet where the converter is installed is IP5X according to EN60529 and no contamination is generated internally. Therefore, the pollution degree can be reduced from degree 3 to 2 (EN62109-1, table 5).

7.2 Clearance

The photovoltaic converter is specified for altitudes up to 3000m, so an altitude correction factor has to be considered for all clearances. The factor is 1.14 (EN62109-1, table F.1).

7.2.1 Clearance used as functional insulation

Only the working voltage is relevant for functional insulation. The impulse-withstand voltage resulting from the overvoltage category is not considered if the required overvoltage category is only 1 (EN62109-1, 7.3.7.3). The worst-case working voltages of the photovoltaic circuit are the blocking voltages of the used semiconductors. Per EN62109-1, table 13, columns 2 and 4, a clearance of 0.9mm is needed for 1200V recurring peak working voltage assuming that semiconductors with 1200V blocking voltage are used for the photovoltaic converter as is typical in the NPC-topology [9]. The value of 0.9mm is the result of linear interpolation between the 960V and 1600V lines of the table with the standard explicitly permitting and rounding to one digit in the safe direction.

$$d = 0.5mm + \frac{1.5mm - 0.5mm}{1600V - 960V} \cdot (1200V - 960V) = 0.875mm \approx 0.9mm$$

Considering the altitude correction factor of 1.14 the needed clearance for functional insulation is 1mm ($=0.875mm \cdot 1.14$). This distance must be taken for the clearances over each semiconductor within the power circuit.

A minimum of two semiconductors have to block the full voltage at the same time in a NPC-topology [9]. A clearance of 1.8mm is necessary for $2 \cdot 1200V = 2400V$ recurring peak working voltage (EN62109-1, table 13, columns 2 and 4).

$$d = 1.5mm + \frac{3.0mm - 1.5mm}{2600V - 1600V} \cdot (2600V - (2 \cdot 1200V)) = 1.8mm$$

Considering the altitude correction factor of 1.14 the necessary clearance for functional insulation is 2.1mm ($\approx 1.8mm \cdot 1.14$).

The required clearance over the transformer is determined by the impulse voltage which is reduced by one overvoltage category by the transformer (EN62109-1, 7.3.7.1.2 c). The grid system voltage of $230V_{rms}$ and overvoltage category 3 correlates to an impulse voltage of 4000V and an overvoltage category 2 with 2500V (EN62109-1, table 12). This means 3mm and 1.5mm clearance (table 13). The difference is 1.5mm. The same procedure must be iterated for the photovoltaic system voltage of $1500V_{dc}$ for overvoltage category 2 (6000V impulse voltage -> 5.5mm clearance) and overvoltage category 1 (4000V impulse voltage -> 3mm clearance). Here the difference is 2.5mm, which is more than was determined for the grid system voltage. Considering the altitude correction factor the needed clearance is 2.9mm ($\approx 2.5mm \cdot 1.14$).

The overvoltage category of the grid voltage between the phases is one category less than to earth (EN62109-1, 7.3.7.1.2 f). Therefore, it is overvoltage category 2 and for a grid system voltage up to 300V this means 2500V impulse voltage (EN62109-1, table 12). According to table 13, the clearance is 1.5mm, which must be multiplied with the altitude correction factor. The required clearance between the phases is 1.8mm ($\approx 1.5mm \cdot 1.14$).

Table 13: Applied working or impulse voltage and related clearance distance from EN62109-1

		DC+	DC-	N	L1' upp	L2' upp	L3' upp	L1' low	L2' low	L3' low	L1'	L2'	L3'	L1	L2	L3
		Maximum applied working voltage or impulse voltage [V]														
DC+	Calculated clearance from EN62109-1, table 13 [mm] under consideration of the altitude correction factor of 1.14 from table F.1		2400	2400	1200	1200	1200	2400	2400	2400	2400	2400	2400	2400	2400	2400
DC-		2.1		2400	2400	2400	2400	1200	1200	1200	2400	2400	2400	2400	2400	2400
N		2.1	2.1		1200	1200	1200	1200	1200	1200	2400	2400	2400	2400	2400	2400
L1'upp		1.0	2.1	1.0		1200	1200	1200	2400	2400	1200	2400	2400	1200	2400	2400
L2'upp		1.0	2.1	1.0	1.0		1200	2400	1200	2400	2400	1200	2400	2400	1200	2400
L3'upp		1.0	2.1	1.0	1.0	1.0		2400	2400	1200	2400	2400	1200	2400	2400	1200
L1'low		2.1	1.0	1.0	1.0	2.1	2.1		1200	1200	1200	2400	2400	1200	2400	2400
L2'low		2.1	1.0	1.0	2.1	1.0	2.1	1.0		1200	2400	1200	2400	2400	1200	2400
L3'low		2.1	1.0	1.0	2.1	2.1	1.0	1.0	1.0		2400	2400	1200	2400	2400	1200
L1'		2.1	2.1	2.1	1.0	2.1	2.1	1.0	2.1	2.1		2400	2400	2000	2000	2000
L2'		2.1	2.1	2.1	2.1	1.0	2.1	2.1	1.0	2.1	2.1		2400	2000	2000	2000
L3'		2.1	2.1	2.1	2.1	2.1	1.0	2.1	2.1	1.0	2.1	2.1		2000	2000	2000
L1		2.1	2.1	2.1	1.0	2.1	2.1	1.0	2.1	2.1	2.9	2.9	2.9		1500	1500
L2		2.1	2.1	2.1	2.1	1.0	2.1	2.1	1.0	2.1	2.9	2.9	2.9	1.8		1500
L3		2.1	2.1	2.1	2.1	2.1	1.0	2.1	2.1	1.0	2.9	2.9	2.9	1.8	1.8	

Black written voltages are the working voltages, blue written are the impulse voltages.

The real voltages within the power circuit can be lower than the blocking voltages and the clearances could be less for this reason. On the other hand, most time the creepage lengths are the stronger request for functional insulation. Therefore it is not a substantial restriction to take the blocking voltage for the determination of the clearances.

7.2.2 Clearance used as basic insulation

The clearance for basic insulation is determined for the photovoltaic circuit and the grid circuit in two steps.

Photovoltaic circuit

The photovoltaic system voltage is $1500V_{dc}$ and overvoltage category 2, which correlates to 6000V impulse voltage (EN62109-1, table 12). The grid system voltage of $230V_{ac}$ and overvoltage category 3 is reduced to overvoltage category 2 for the photovoltaic circuit by the transformer, which means 2500V impulse voltage. The demand from the photovoltaic system voltage is higher (6000V to 2500V impulse voltage) and therefore this has to be taken for the determination of the clearance from table 13, what is here 5.5mm. Considering the altitude correction factor the needed clearance for basic insulation in the photovoltaic circuit is 6.3mm ($\approx 5.5mm \cdot 1.14$).

Grid circuit

The grid system voltage of $230V_{ac}$ and overvoltage category 3 correlates to 4000V impulse voltage. The photovoltaic system voltage of $1500V_{dc}$ for overvoltage category 2 is reduced to overvoltage category 1 for the grid circuit by the transformer, which again means 4000V impulse voltage. For 4000V impulse voltage the clearance is 3mm. Considering the altitude correction factor the clearance for basic insulation of the grid circuit is 3.5mm ($\approx 3mm \cdot 1.14$).

Table 14: Determination of the clearance for photovoltaic and grid circuit from EN62109-1		
	Photovoltaic circuit	Grid circuit
System voltage	1500V _{dc}	230V _{rms}
Overvoltage category	2	3
Resulting impulse voltage	6000V	4000V
Reduced overvoltage category for other circuit due to transformer	2	1
Resulting impulse voltage for other circuit	2500V	4000V
Relevant impulse voltage	6000V	4000V
Clearance for basic insulation (EN62109-1, table 13)	5.5mm	3.0mm
Clearance for basic insulation considering the altitude correction factor of 1.14 here	6.3mm	3.5mm
Clearance for protective separation	8mm	5.5mm
Clearance for protective separation considering the altitude correction factor	9.2mm	6.3mm

7.2.3 Clearance used as protective separation

The system voltage, the overvoltage category, and the determination of the resulting impulse voltage are the same as for basic insulation. The required clearance is higher for protective separation than for basic insulation because a failure could be fatal for the user. The impulse voltage corresponding to the next higher value in the table shall be used for protective separation realized by reinforced insulation (EN62109-1, 7.3.7.4.1). Therefore the relevant impulse voltage is 8000V for the photovoltaic circuit and 6000V for the grid circuit (instead of 6000V and 4000V for basic insulation). The clearance for the photovoltaic circuit is 8mm and 5.5mm for the grid circuit (EN62109-1, table 13). Considering the altitude correction factor the needed clearance for reinforced insulation is 9.2mm ($\approx 8\text{mm} \cdot 1.14$) for the photovoltaic circuit and 6.3mm ($\approx 5.5\text{mm} \cdot 1.14$) for the grid circuit. These distances must be taken for all clearances between power circuit, e.g. input terminals, output terminals, DC-link or IGBT-gates, and the solar controller electronics, e.g. customer interface and current sensor feedback.

7.3 Creepage

Potting or coating material may be used on PCBs to protect against pollution but also improves the microenvironment of the parts underneath the protection (EN62109-1, 7.3.7.6). When coating is used to reduce the effective pollution degree for the purposes of reduced spacing requirements, it is called a "conformal coating" and, pollution degree 1 applies for the coated area. The potting or coating material must pass a test according to EN60664-3.

For the discussed photovoltaic converter it is assumed that neither potting nor coating material is used to protect against pollution.

The photovoltaic converter considered here consists of a PCB only and no other insulation pertinent components are used. Column 3 of EN62109-1, table 14 is relevant for the creepage up to voltages of 1250V. The isolation category of the insulation is considered by taking the creepage distance from column 5 to 8 for higher voltages or other insulators than PCBs, e.g. a foil between DC+ and DC-. For all creepages, interpolation is explicitly permitted.

The shift between the primary and secondary voltage of the transformer is unknown but it must be considered by adding RMS-voltages. This is why the worst case is considered and the quadratic sum of voltages is used.

7.3.1 Creepage used as functional insulation

The grid voltage of 400V between phases L1, L2 and L3 is stepped down by the transformer by a 2:1 ratio. Therefore, the voltages between the phases L1', L2' and L3' are 200V.

$$V_{L1',L2'} = V_{L2',L3'} = V_{L1',L3'} = 200V$$

If no load is applied to the photovoltaic converter the DC-link will be exposed to the maximum photovoltaic voltage which is in this case $V_{DC+,DC-} = 1500V$. The solar controller makes sure that the total DC-voltage is well shared between the upper (between DC+ and N) and lower (between N and DC-) DC-link. Therefore the maximum applied voltage is here 750V.

$$V_{DC+N} = V_{DC-,N} = 750V$$

The voltages over the individual IGBTs and diodes of the module can be calculated by their voltage duty cycles which depend on the modulation index, M , of the converter [9]. The phase shift, φ , between voltage and current waveform affects neither the voltage duty cycle nor the modulation index.

$$M = \frac{\text{peak voltage between the phases}}{0,5 \cdot V_{dc}} = \frac{V_{L',L'} \cdot \sqrt{2}}{0,5 \cdot V_{dc}} = \frac{200V \cdot \sqrt{2}}{0,5 \cdot 1500V} = 0.377$$

The voltage duty cycle of the outer IGBTs is $1 - \frac{M}{\pi} = 1 - \frac{0.377}{\pi} = 0.88$. On the inner IGBTs and the central diodes it is $\frac{M}{\pi} = \frac{0.377}{\pi} = 0.12$.

$$V_{DC+,L'upper} = V_{DC-,L'lower} = \sqrt{\frac{1}{T} \int_0^T \left(\left(1 - \frac{M}{\pi}\right) \cdot 0.5 \cdot V_{dc} \right)^2 dt} = \left(1 - \frac{M}{\pi}\right) \cdot 0.5 \cdot V_{dc} = 0.88 \cdot 0.5 \cdot 1500V = 660V$$

$$V_{L1',L1'upper} = V_{L1',L1'lower} = V_{N,L'upper} = V_{N,L'lower} = \sqrt{\frac{1}{T} \int_0^T \left(\frac{M}{\pi} \cdot 0.5 \cdot V_{dc} \right)^2 dt} = \frac{M}{\pi} \cdot 0.5 \cdot V_{dc} = 0.12 \cdot 0.5 \cdot 1500V = 90V$$

All other voltages can be calculated as follows:

$$V_{L',DC+} = V_{DC+,L'upper} + V_{L1',L1'upper} = 660V + 90V = 750V$$

$$V_{DC+,L'lower} = V_{DC-,L'upper} = V_{dc} - V_{DC+,L'upper} = 1500V - 660V = 840V$$

$$V_{L1'upper,L1'lower} = V_{L2'upper,L2'lower} = V_{L3'upper,L3'lower} = V_{L1',L1'upper} + V_{L1',L1'lower} = 90V + 90V = 180V$$

$$V_{L1'upper,L2'upper} = V_{L1'lower,L2'lower} = \frac{V_{DC+,L'upper}}{V_{L',DC+}} \cdot V_{L',L'} = \frac{660V}{750V} \cdot 200V = 176V$$

$$V_{L1',L2'upper} = V_{L1',L2'lower} = \sqrt{V_{L1',L2'}^2 + V_{L1',L1'lower}^2} = \sqrt{200V^2 + 90V^2} = 219V$$

$$V_{L1'upper,L2'lower} = \sqrt{V_{L1'upper,L2'upper}^2 + V_{L1'upper,L1'lower}^2} = \sqrt{176V^2 + 180V^2} = 252V$$

$$V_{L1',N} = \sqrt{V_{N,L1'upper}^2 + V_{L1',L1'upper}^2} = \sqrt{90V^2 + 90V^2} = 128V$$

The DC-potential is connected to earth with a grounding resistor in this example here. Therefore, the voltages to earth are:

$$V_{DC-,earth} = 0V$$

$$V_{N,earth} = V_{DC-,earth} + V_{DC-,N} = 0V + 750V = 750V$$

$$V_{DC+,earth} = V_{DC-,earth} + V_{dc} = 0V + 1500V = 1500V$$

For the calculation of the voltage from the secondary phases L1', L2' and L3' to the earthed DC- it makes sense to take a modified equivalent circuit diagram for better understanding. There the DC- is not connected to earth with a resistor. Instead, the star point of the grid transformer is grounded. This modified circuit is more or less the same as was explained in the AC drive example before. In that case, the voltage from DC+ or DC- to earth is half of the DC-voltage. Therefore, the voltage from DC-midpoint to earth is 0V.

Figure 5: Modified grounding of the photovoltaic converter

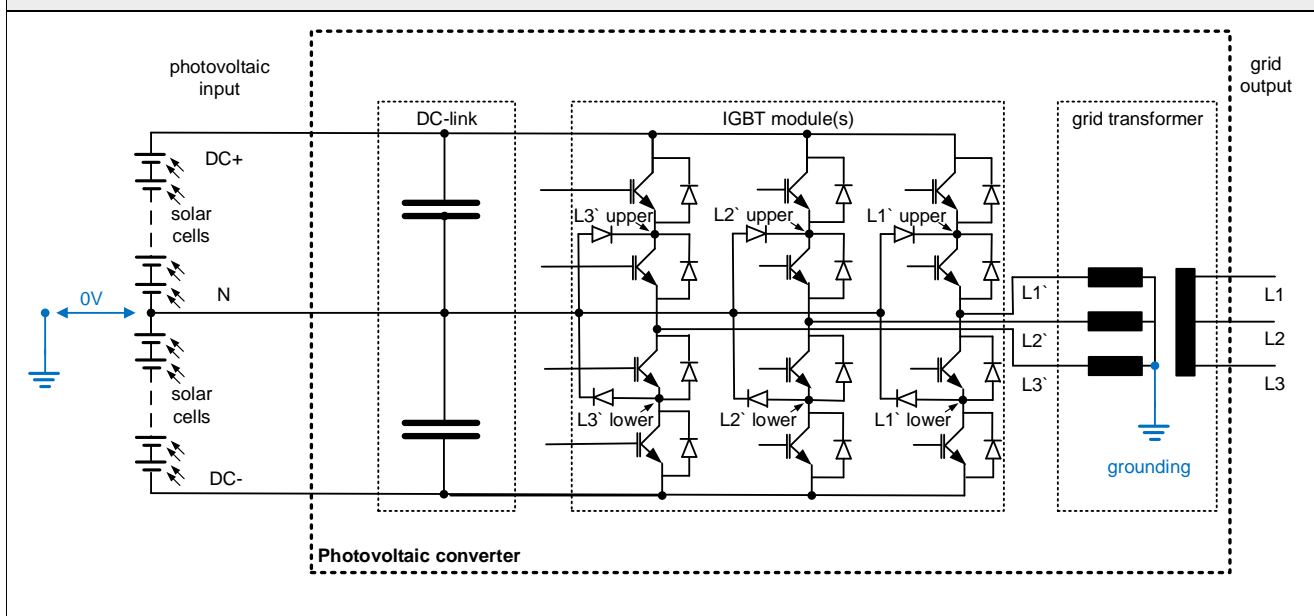

This means that it is the same if the star point of the transformer or the DC-midpoint is connected to earth. If the transformer is floating and DC- is connected to earth, the voltage from the transformer star point to earth will be half of the DC-link voltage. Knowing this it is easy to calculate the voltages from the photovoltaic circuit to earth:

$$V_{L,DC-} = V_{L,earth} = 400V / \sqrt{3} = 230V$$

$$V_{L,DC+} = V_{L,earth} + V_{dc} = 230V + 1500V = 1730V$$

$$V_{L,N} = V_{L,earth} + 0.5 \cdot V_{dc} = 230V + 0.5 \cdot 1500V = 980V$$

It must be considered that the transformer input and output voltages can be arbitrarily phase shifted (depending on the numerical index of the transformer vector group):

$$V_{L,L'} = V_{L,DC+} - V_{L',DC+} = 1730V - 750V = 980V$$

$$V_{L,L'upper} = V_{L,DC+} - V_{DC+,L'upper} = 1730V - 660V = 1070V$$

$$V_{L,L'lower} = V_{L,DC-} + V_{DC-,L'lower} = 230V + 660V = 890V$$

The creepages are taken from EN62109-1, table 14, column 3 based on these voltages. Not all voltage levels are given in table 14, so the explicitly permitted interpolation can be used. For the voltage $V_{L1,L1'} = 980V$ for example is the creepage calculated to:

$$d_{L1,L1'} = 4mm + \frac{5mm - 4mm}{1000V - 800V} \cdot 180V = 4.9mm$$

Table 15: Applied RMS voltage and related creepage distance from EN62109-1, table 14

		DC+	DC-	N	L1' upp	L2' upp	L3' upp	L1' low	L2' low	L3' low	L1'	L2'	L3'	L1	L2	L3
		Applied RMS voltage [V]														
DC+	Calculated creepage from EN62109-1, table 14 [mm] for a PCB		1500	750	660	660	660	840	840	840	750	750	750	1730	1730	1730
DC-		7.6		750	840	840	840	660	660	660	750	750	750	230	230	230
N		3.8	3.8		90	90	90	90	90	90	128	128	128	980	980	980
L1'upp		3.4	4.2	1.0		176	176	180	252	252	90	219	219	1070	1070	1070
L2'upp		3.4	4.2	1.0	1.0		176	252	180	252	219	90	219	1070	1070	1070
L3'upp		3.4	4.2	1.0	1.0	1.0		252	252	180	219	219	90	1070	1070	1070
L1'low		4.2	3.4	1.0	1.0	2.1	2.1		176	176	90	219	219	890	890	890
L2'low		4.2	3.4	1.0	2.1	1.0	2.1	1.0		176	219	90	219	890	890	890
L3'low		4.2	3.4	1.0	2.1	2.1	1.0	1.0	1.0		219	219	90	890	890	890
L1'		3.8	3.8	2.1	1.0	2.1	2.1	1.0	2.1	2.1		200	200	980	980	980
L2'		3.8	3.8	2.1	2.1	1.0	2.1	2.1	1.0	2.1	2.1		200	980	980	980
L3'		3.8	3.8	2.1	2.1	2.1	1.0	2.1	2.1	1.0	2.1	2.1		980	980	980
L1		8.7	2.1	4.9	5.4	5.4	5.4	4.5	4.5	4.5	4.9	4.9	4.9		400	400
L2		8.7	2.1	4.9	5.4	5.4	5.4	4.5	4.5	4.5	4.9	4.9	4.9	2		400
L3		8.7	2.1	4.9	5.4	5.4	5.4	4.5	4.5	4.5	4.9	4.9	4.9	2	2	

The creepage must have at least the distance of the determined clearance. **Increased distance values due to the clearance requirement from Table 13 are marked blue here.**

7.3.2 Creepage used as basic insulation

The applied voltages over the basic insulation were calculated for functional insulation due to the earthed DC-. It must also be checked if the clearance is higher than the creepage. If necessary, the creepage must be increased to the clearance level.

Table 16: Applied RMS voltage and required creepage distance for basic insulation

	L1, L2, L3	L1', L2', L3'	L1'upp, L2'upp, L3'upp	L1'low, L2'low, L3'low	DC+	N	DC-
Applied RMS voltage [V]	230	750	840	660	1500	750	0
Creepage distance from EN62109-1, table 14 [mm]	0.9	3.8	4.2	3.4	7.6	3.8	0
Required creepage distance considering the clearance with the altitude correction factor of 1.14 here [mm]	3.5	6.3	6.3	6.3	7.6	6.3	6.3

7.3.3 Creepage used as protective separation

The voltages for determining the creepages for protective separation realized by reinforced or double insulation are the same as for basic insulation, but the requirements for the creepage length are higher. The distances from EN62109-1, table 14 must be doubled (EN62109-1, 7.3.7.5.1). Again, it must also be

checked if the clearance is higher than the doubled creepage. If necessary, the creepage must be increased to the clearance level.

Table 17: Applied RMS voltage and required creepage distance for protective separation							
	L1, L2, L3	L1', L2', L3'	L1'upp, L2'upp, L3'upp	L1'low, L2'low, L3'low	DC+	N	DC-
Applied RMS voltage [V]	230	750	840	660	1500	750	0
Double creepage distance from EN62109-1, table 14 [mm]	1.7	7.6	8.4	6.7	15.1	7.6	0
Required creepage distance considering the clearance [mm]	6.3	9.2	9.2	9.2	15.1	9.2	9.2

7.4 Solid insulation

Potting or coating material may be used on PCBs as solid insulation. For this, the potting or coating material must pass a test according to EN60664-3 (EN62109-1, 7.3.7.8.4.2).

In this example, it is assumed that the photovoltaic converter does not have potting or coating material as solid insulation.

For the inner layers of multi-layer PCBs, the insulation between adjacent tracks on the same layer shall be treated either as a creepage for pollution degree 1 and a clearance in air (see requirements above) or as solid insulation (EN62109-1, 7.3.7.8.4.1).

7.4.1 Solid insulation used as functional insulation

The standard has no special requirements for functional insulation, only the determination of the relevant voltage is described (EN62109-1, 7.3.7.3 and 7.3.7.8.2.2). No test is necessary.

7.4.2 Solid insulation used as basic insulation

Insulation material thinner than 700µm must not be subjected to mechanical stress, which is the case for the inner layer of a PCB. Two tests must be performed on components and subassemblies in order to ensure that the solid insulation withstands the voltage stress.

An impulse withstand voltage test must be performed as a type test according to EN62109, table 15. The test voltage of the photovoltaic converter is 4000V for the grid circuit (EN62109-1, table 16, column 4 for 300V because interpolation is not permitted) and 2034V for the photovoltaic circuit (EN62109-1, table 16, column 2 and interpolation for 230V).

A dielectric strength test must be performed both as a type test and as a routine test (EN62109-1, 7.3.7.8.2.1). The test voltages are 1430V_{ac} or 2020V_{dc} for the grid circuit (EN62109-1, table 17, column 2 for 230V) and 1684V_{ac} or 2434V_{dc} for the photovoltaic circuit (EN62109-1, table 18, column 2 for 1500V).

7.4.3 Solid insulation used as protective separation

The considered photovoltaic converter has protective separation only towards the photovoltaic circuit. There are optocouplers for the PWM signals and transformers for the supply of the IGBT gate drivers. All these components are mounted on a PCB. If the insulation thickness per layer is less than 0.2mm, at least three material layers will be required for protective separation. For thicker material two layers are sufficient (EN62109-1, 7.3.7.8.3.2). For protective separation three tests must be performed on components, subassemblies, and layers of multilayer PCBs.

An impulse withstand voltage test must be done as a type test. A sample test shall be performed if the insulation consists of a single layer of material additionally (EN62109-1, 7.3.7.8.2.1). The impulse test voltage is 6000V for the grid circuit (EN62109-1, table 16, column 5 for 300V) and 2300V for the photovoltaic circuit (EN62109-1, table 16, column 3 for 230V).

A dielectric strength test must be performed as a type test for the grid- and the photovoltaic circuit. The grid circuit test voltage is 2860V_{ac} or 4044V_{dc} (EN62109-1, table 17, column 3 for 230V) and the photovoltaic circuit test voltage is 2784V_{ac} or 3867V_{dc} (EN62109-1, table 18, column 3 for 1500V). A routine test of the photovoltaic circuit is necessary additionally for the used IGBT power supply transformers with a test voltage of 1684V_{ac} or 2434V_{dc} (EN62109-1, table 18, column 2 for 1500V).

For voltages higher than $700V_{peak}$ and voltage stress higher than $1000V/mm$ through the solid insulation is a partial discharge test as a type and sample test needed (EN62109-1, 7.3.7.8.2.1). The rated discharge voltage is the sum of the recurring peak voltages in each of the circuits separated by the insulation (EN612109-1, table 19) what is the maximum photovoltaic voltage (here $1500V$) plus some transient voltage from IGBT switching (here only $50V$ because the load current is strongly limited at the maximum photovoltaic voltage that no transient overvoltage occurs). The minimum partial discharge extinction voltage is

$V_{PDextinction} = 1.5 \cdot V_{recurring\ peak} = 1.5 \cdot (1500V + 50V) = 2325V$. This is the minimum peak-value of the 50Hz or 60Hz partial discharge test voltage.

7.5 Summary photovoltaic converter

The results of the insulation coordination according to EN62109-1 for the example with 3000m altitude are summarized in the following table:

Table 18: Insulation requirements of the photovoltaic converter according to EN62109-1				
EN62109-1		Type of insulation		
		Functional insulation	Basic insulation	Protective separation
Realization of insulation	Clearance	1.0mm to 2.9mm	3.5mm and 6.3mm	6.3mm and 9.2mm
	Creepage	1.0mm to 8.7mm	3.5mm to 7.6mm	6.3mm to 15.1mm
	Solid insulation			
	Impulse withstand test voltage	-	2034V ^a and 4000V ^b	2300V ^a and 6000V ^b
	AC or DC test voltage	-	1430V _{ac} ^a and 1684V _{ac} ^b	2860V _{ac} ^a and 2784V _{ac} ^b
	Partial discharge extinction voltage	-	-	2325V _{peak} ^b
^a for grid circuit		^b for photovoltaic circuit		

It is helpful to know that the UL standard UL1741, which is often used for photovoltaic converters, has above all one relevant difference to the EN62109-1. UL does not allow for derating the pollution degree inside of a converter from 3 to 2 when enclosure fulfills protection class IP54. Derating is only possible if:

- PCBs are covered by a coating which provides an uninterrupted covering over at least one side and the complete distance up to the other side of conductive material or,
- Pollution degree 1 is achievable at a specific printed wiring board location by application of at least a 0.79mm thick layer of silicone rubber for a group of printed wiring boards through potting, without air bubbles, in epoxy or potting material (UL1741, 25.4).

Figure 1: Types of insulation	3
Figure 2: Structure of selected standards for the coordination of insulation of converters.....	7
Figure 3: Principal schematic of the AC drive.....	9
Figure 4: Principal schematic of the photovoltaic converter	15
Figure 5: Modified grounding of the photovoltaic converter	20
Table 1: Overvoltage categories according to EN61800-5-1, 4.3.6.1.3.....	3
Table 2: Altitude correction factor according to EN60664-1, table A2	4
Table 3: Pollution degrees according to EN61800-5-1, 4.3.6.1.2	4
Table 4: Comparative tracking index (CTI) groups	5
Table 5: Selection of European standards for the coordination of insulation.....	6
Table 6: Selection of UL standards for the coordination of insulation	6
Table 7: Typical specification SEMIKRON uses for the coordination of insulation according to EN61800-5-1.8	12
Table 8: Applied RMS voltage and related creepage distance for functional insulation from EN61800-5-1..	12
Table 9: Applied RMS voltage and required creepage distance for functional insulation of the AC drive	12
Table 10: Applied RMS voltage and required creepage distance for basic insulation	13
Table 11: Applied RMS voltage and required creepage distance for protective separation.....	13
Table 12: Insulation requirements of the AC drive according to EN61800-5-1.....	14
Table 13: Applied working or impulse voltage and related clearance distance from EN62109-1.....	17
Table 14: Determination of the clearance for photovoltaic and grid circuit from EN62109-1	18
Table 15: Applied RMS voltage and related creepage distance from EN62109-1, table 14	21
Table 16: Applied RMS voltage and required creepage distance for basic insulation	21
Table 17: Applied RMS voltage and required creepage distance for protective separation.....	22
Table 18: Insulation requirements of the photovoltaic converter according to EN62109-1	23

Symbols and Terms

Letter Symbol	Term
hPa	hecto Pascal; $1\text{hPa} = 0.01\text{N} / \text{m}^2 = 0.01\text{kg} / \text{m} \cdot \text{s}^2$
NPC	Neutral Point Clamped, explanation see [9]
V_{isol}	Insulation test voltage (r.m.s.), applied between module base plate or substrate backside and shorted module power circuit terminals

A detailed explanation of the terms and symbols can be found in the "Application Manual Power Semiconductors" [2]

References

- [1] www.SEMIKRON.com
- [2] A. Wintrich, U. Nicolai, W. Tursky, T. Reimann, "Application Manual Power Semiconductors", ISLE Verlag 2015, ISBN 978-3-938843-83-3
- [3] EN60664-1: 2007, Insulation coordination for equipment within low-voltage systems – Part 1: Principles, requirements and tests
- [4] EN62477-1: 2012, Safety requirements for power electronic converter systems and equipment – Part 1: General
- [5] EN61800-5-1: 2008, Adjustable speed electrical power drive systems – Part 5-1: Safety requirements – Electrical, thermal and energy
- [6] EN62109-1: 2010, Safety of power converters for use in photovoltaic power systems – Part 1: General requirements
- [7] UL61800-5-1: 2012, Adjustable speed electrical power drive systems – Part 5-1: Safety requirements – Electrical, thermal and energy
- [8] www.ul.com/global/documents/offerings/industries/powerandcontrols/powerdistribution/041013_UL_508C_Continuing_Cert_.pdf, accessed on 28.07.2016
- [9] Ingo Staudt, "3L NPC & TNPC Topology", SEMIKRON application note, AN11001 – rev05, Nuremberg, 2015

IMPORTANT INFORMATION AND WARNINGS

The information in this document may not be considered as guarantee or assurance of product characteristics ("Beschaffenheitsgarantie"). This document describes only the usual characteristics of products to be expected in typical applications, which may still vary depending on the specific application. Therefore, products must be tested for the respective application in advance. Application adjustments may be necessary. The user of SEMIKRON products is responsible for the safety of their applications embedding SEMIKRON products and must take adequate safety measures to prevent the applications from causing a physical injury, fire or other problem if any of SEMIKRON products become faulty. The user is responsible to make sure that the application design is compliant with all applicable laws, regulations, norms and standards. Except as otherwise explicitly approved by SEMIKRON in a written document signed by authorized representatives of SEMIKRON, SEMIKRON products may not be used in any applications where a failure of the product or any consequences of the use thereof can reasonably be expected to result in personal injury. No representation or warranty is given and no liability is assumed with respect to the accuracy, completeness and/or use of any information herein, including without limitation, warranties of non-infringement of intellectual property rights of any third party. SEMIKRON does not assume any liability arising out of the applications or use of any product; neither does it convey any license under its patent rights, copyrights, trade secrets or other intellectual property rights, nor the rights of others. SEMIKRON makes no representation or warranty of non-infringement or alleged non-infringement of intellectual property rights of any third party which may arise from applications. This document supersedes and replaces all information previously supplied and may be superseded by updates. SEMIKRON reserves the right to make changes.

SEMIKRON INTERNATIONAL GmbH
Sigmundstrasse 200, 90431 Nuremberg, Germany
Tel: +49 911 6559 6663, Fax: +49 911 6559 262
sales@semikron.com, www.semikron.com